

UNIQUE

Dieroom Equipment

 **DICAR**[®]



www.dicar.eu

CUTTING - BENDING - NOTCHING - NICK GRINDING

UC-04
CUTTING

Straight and double miter (Lipper) cutting machine.

Rule thickness	3 - 4 pt
Cutting height	23,8 - 50 mm
Miter angle	54° (54+9 double angle and 42° optional)
Caliper	500 mm Digital
Cutting edge lifetime	200.000
Grinding option	0,15 mm x 10 times
Precision	0,01 mm
Dimensions	300 x 900 x 550 mm
Weight	45 kg

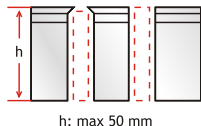

UCN-02
CUTTING
and **NOTCHING**
Notching and Straight single miter (Lipper) cutting machine.

Rule thickness	1,5 - 3 pt
Rule height	23,8 - 30 mm
Miter angle	54° (54+9 double angle and 42° optional)
Caliper	500 mm Digital
Cutting knife lifetime	300.000
Grinding option	0,15 mm x 10 times
Notching height	12 - 19 mm
Notching width	3 - 8 mm
Precision	0,01 mm
Dimensions	250 x 850 x 350 mm
Gross weight	27 kg

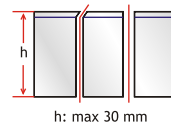
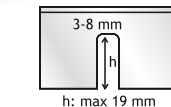

UC-05
CUTTING

Straight and single miter (Lipper) cutting machine.

Rule thickness	1,5 - 6 pt
Cutting height	8 - 50 mm
Miter angle	54° (54+9 double angle and 42° optional)
Caliper	500 mm Digital
Cutting edge lifetime	200.000
Grinding option	0,15 mm x 10 times
Precision	0,01 mm
Dimensions	400 x 1030 x 620 mm
Weight	80 kg

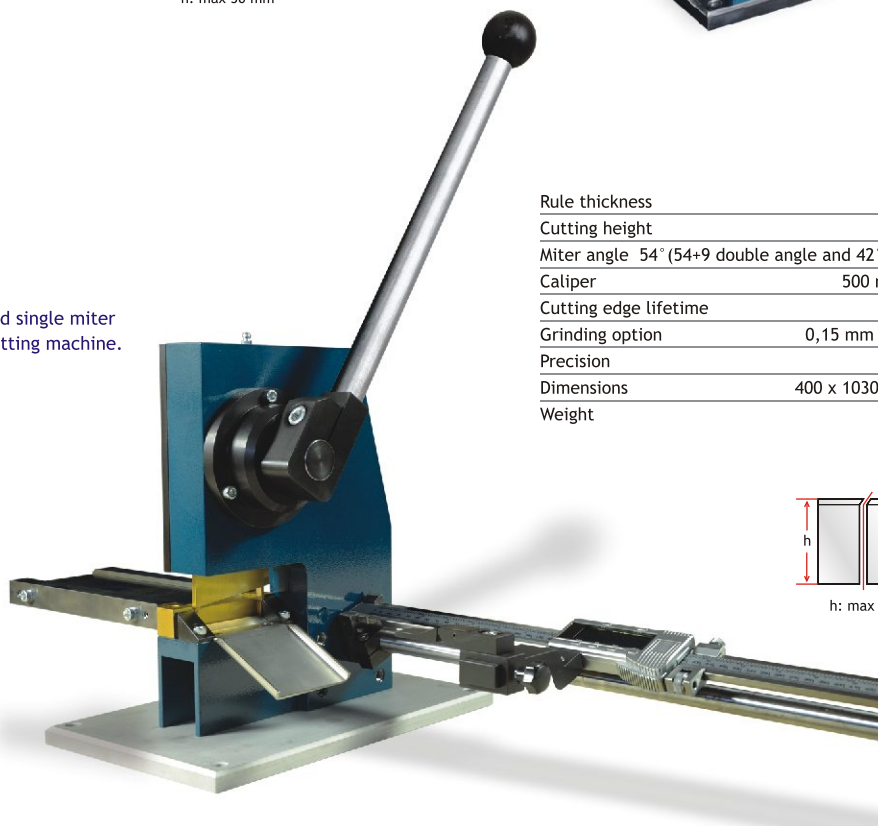
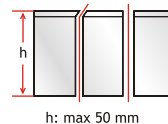

UH-01
CUTTING

Creasing matrix cutting machine.

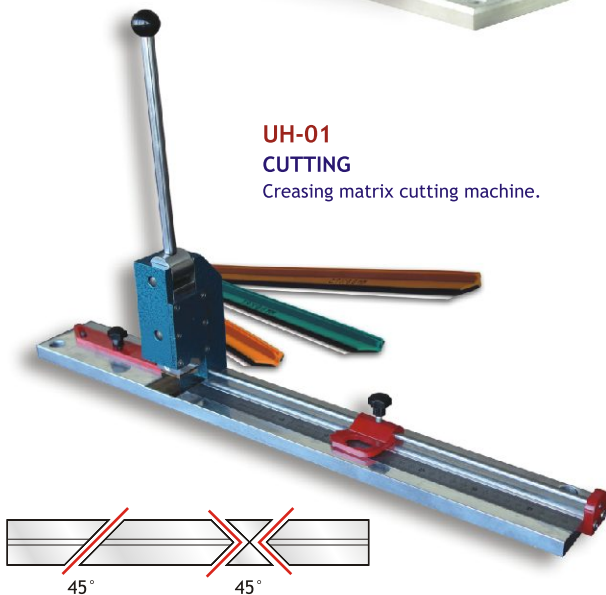

UCN-01
CUTTING and **NOTCHING**
Notching and Straight single miter (Lipper) cutting machine.

Rule thickness	3 - 6 pt
Rule height	23,8 - 30 mm
Miter angle	54° (54+9 double angle and 42° optional)
Caliper	500 mm Digital
Cutting knife lifetime	200.000
Grinding option	0,15 mm x 10 times
Notching height	12 - 19 mm
Notching width	8 - 10 mm
Precision	0,01 mm
Dimensions	400 x 1030 x 620 mm
Gross weight	60 kg

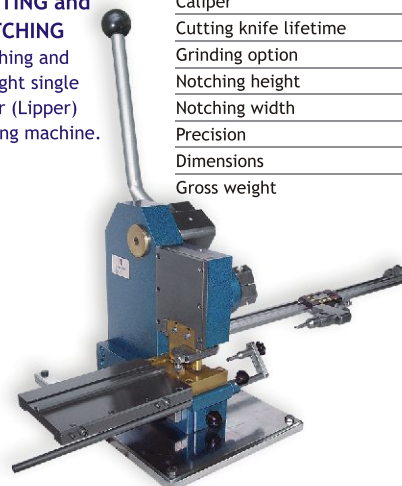
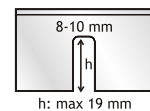
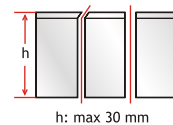

Rule thickness	1,5 - 4 pt
Rule height	8 - 30 mm (Opt.: 50 mm)
Bending width	Please see bending tools
Side gauge	300 mm
Precision	0,01 mm
Dimensions	350 x 450 x 570 mm
Gross weight	45 kg

UB-01
BENDING
Hand levered
bending machine.

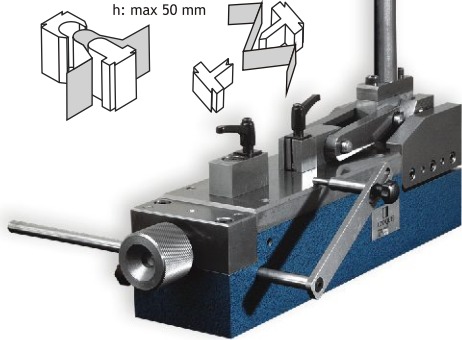

UB-05
BENDING
Circle bending
machine.

Rule thickness	1,5 - 4 pt
Rule height	8 - 30 mm (Optional 50 mm)
Bending width	Please see bending tools
Side gauge	400 mm
Precision	0,01 mm
Dimensions	500 x 1100 x 270 mm
Gross weight	66 kg

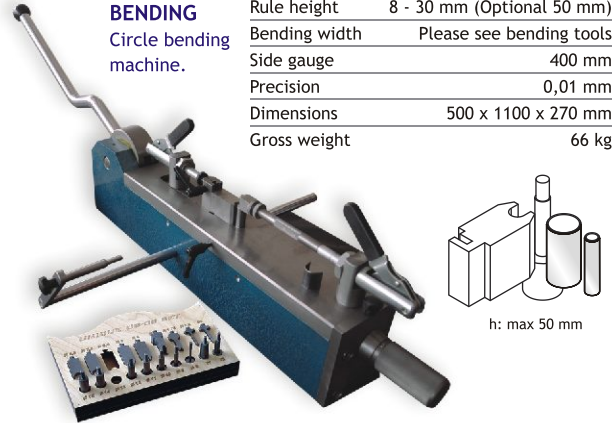

UB-02
BENDING
Foot levered bending machine.

Rule thickness	1,5 - 4 pt
Rule height	8 - 50 mm
Bending width	Please see bending tools
Side gauge	500 mm digital
Precision	0,01 mm
Dimensions	600 x 1230 x 1320 mm
Gross weight	130 kg

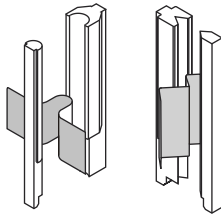

UB-06
BENDING
Circle bending
machine.

Rule thickness	2 - 4 pt
Rule height	23,8 - 50 mm
Bending width	min. Ø 40 mm
Side gauge	n/a
Precision	0,01 mm
Dimensions	215 x 400 x 310 mm
Gross weight	44 kg

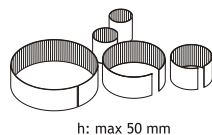

UB-00
BENDING
Hand levered
bending machine.

Rule thickness	1,5 - 4 pt
Bending height	8 - 30 mm (Optional 50 mm)
Bending width	Please see bending tools
Bending tools	Available to use UB-01, UB-05 and slot bending tools
Working style	Down and up hand bending option
Side gauge	Sensitive adjustment with 25 mm micrometer
Precision	0,01 mm
Dimensions	545 X 930 X 240 mm
Weight	50 kg





UB-08
BENDING
Foot levered bending machine

Rule thickness (23,8 - 50 mm)	3 - 4 pt
Rule thickness (50 - 100 mm)	3 pt
Rule height	23,8 - 100 mm
Bending width	Please see bending tools
Side gauge	500 mm digital
Precision	0,01 mm
Dimensions	730 x 1300 x 1200 mm
Gross weight	160 kg

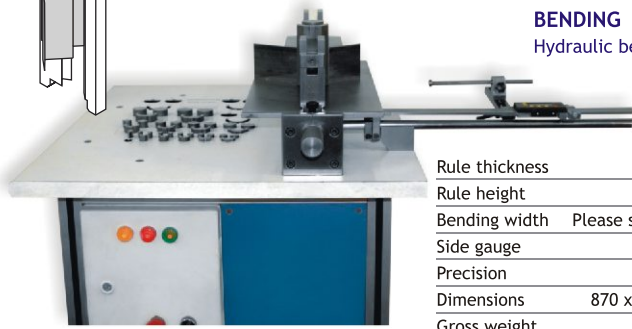
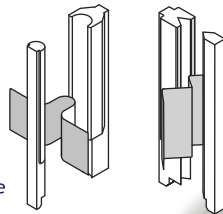

UB-08h
BENDING
Hydraulic bending machine.

Rule thickness	3 - 4 pt
Rule height	23,8 - 100 mm
Bending width	Please see bending tools
Side gauge	500 mm digital
Precision	0,01 mm
Dimensions	870 x 1300 x 1250 mm
Gross weight	200 kg

UN-04
NOTCHING
Notching machine.

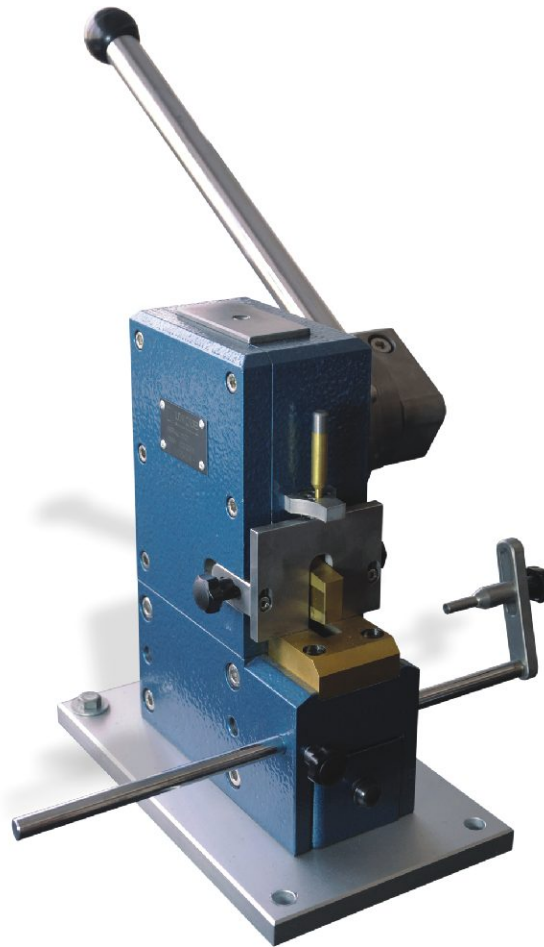
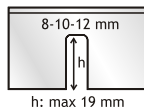

Rule thickness	2-6 pt
Notching height	8-19 mm
Notching width	3-12 mm
Side gauge	250 mm
Cutting knife lifetime	200.000
Grinding option	0,15 mm x 10 time
Precision	0,01 mm
Dimensions	308 x 250 x 400 mm
Gross weight	40 kg

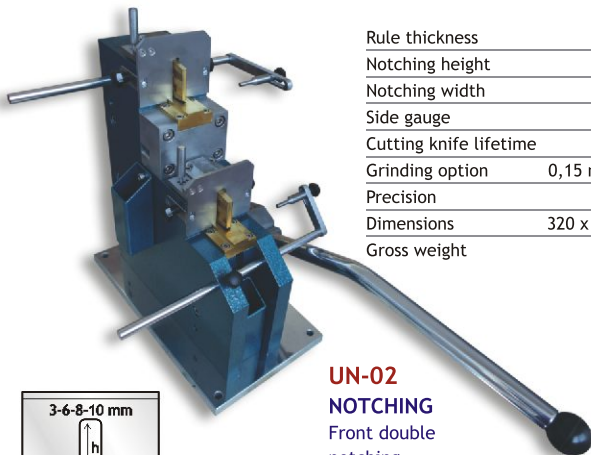

Rule thickness	2 - 3 pt
Notching height	8 - 19 mm
Notching width	3 - 10 mm
Side gauge	250 mm
Cutting knife lifetime	250.000
Grinding option	0,15 mm x 10 times
Precision	0,01 mm
Dimensions	320 x 500 x 410 mm
Gross weight	65 kg

UN-02
NOTCHING
Front double notching machine.

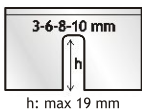

Rule thickness	2 - 3 pt
Notching height	8 - 19 mm
Notching width	3 - 8 mm
Side gauge	250 mm
Cutting knife lifetime	250.000
Grinding option	0,15 mm x 10 times
Precision	0,01 mm
Dimensions	300 x 600 x 280 mm
Gross weight	55 kg

UN-03
NOTCHING
Front & back double notching machine.

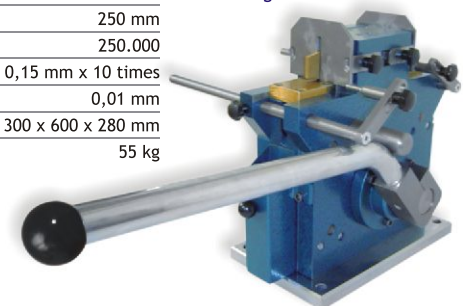
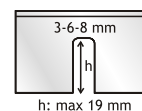

Grinding width	0,1 - 2mm
Grinding height	0,1 - 7mm
Grinding disc diameter	50 mm
Min. grid stone size	30 mm
Engine type	Electric
Power	600 W
RPM	27000 rpm
Input voltage	220V / 50 Hz

UEN-01
NICK
Electric nick grinder

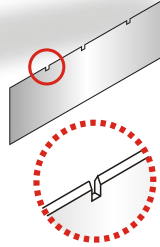
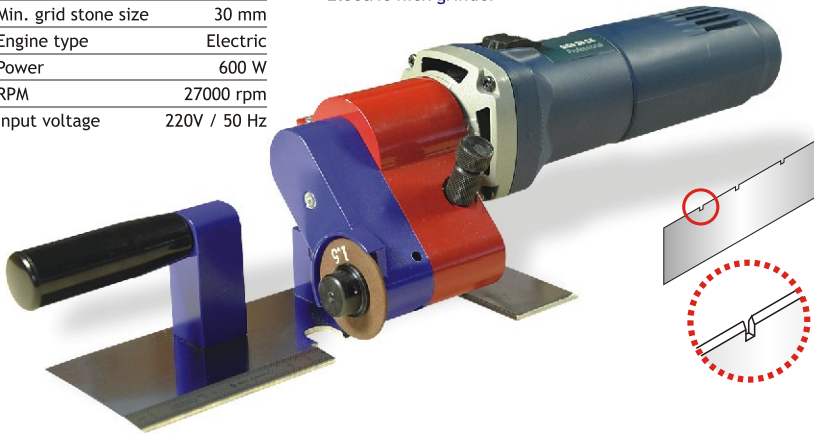

Grinding width	0,1 - 1,5mm
Grinding height	0,1 - 7mm
Grinding disc diameter	50 mm
Min. grid stone size	30 mm
Engine type	Air
Airflow	285 lt/min
Pressure	90 psi / 6,2 bar
RPM	28000 rpm
Dimensions	120 x 250 x 120 mm

UHN-01
NICK
Air - Driven nick grinder

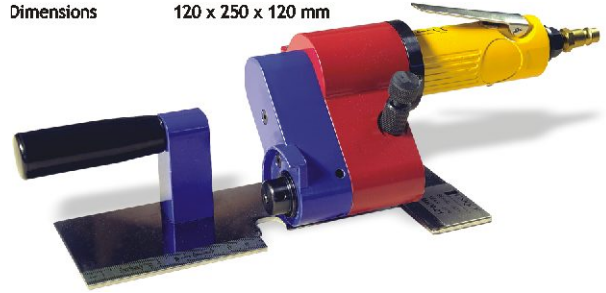

URN-01
ROTARY NOTCHING
Rotary notching machine.

Rule thickness	3 - 6 pt
Notching height	0 - 19 mm
Notching width	8 - 12 mm
Side gauge	250 mm
Cutting knife lifetime	200.000
Grinding option	0,15 mm x 10 times
Precision	0,01 mm
Dimensions	308 x 250 x 400 mm
Gross weight	40 kg

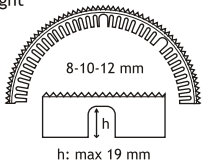
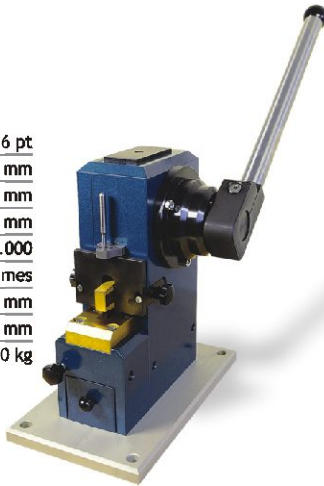

URC-01
ROTARY CUTTING
Rotary, straight and single miter (Lipper) cutting machine.

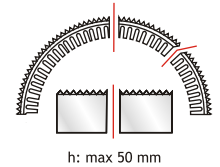

Rule thickness	3 - 4 pt
Cutting height	23,8 - 50 mm
Miter angle	28° (54, 54+9 ve 42° optional)
Caliper	500 mm Digital
Cutting edge lifetime	200.000
Grinding option	0,15 mm x 10 times
Precision	0,01 mm
Dimensions	200 x 900 x 400 mm
Weight	30 kg

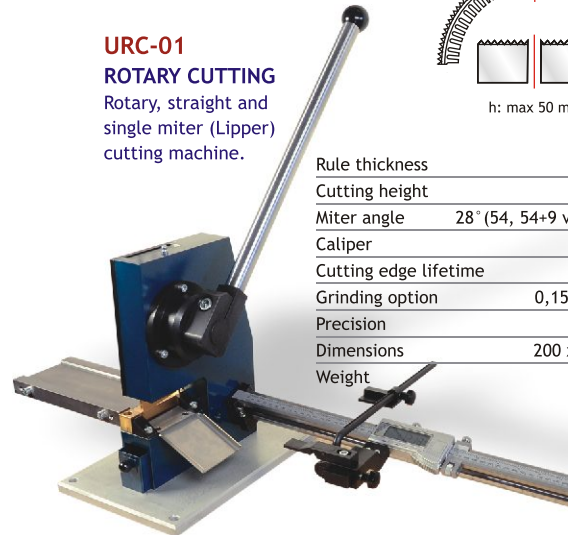

URC-03
ROTARY
Rotary cushion crease cutting machine.

Material	Cushion crease
Cutting width	Max. 13,5 mm
Width	Max. 35 mm
Caliper	750 mm
Cutting edge lifetime	150.000
Cutting angle	90° - 45°
Precision	0,01 mm
Air pressure	6 - 8 bar
Dimensions	180 x 180 x 1000 mm
Gross weight	25 kg

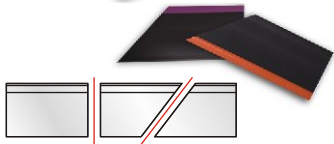

URC-04
ROTARY
Rotary radius cutting machine.

Rule thickness	3 - 6 pt
Rule height	23,8 - 30 mm
Radius diameter	R5 - R3
Cutting knife lifetime	200.000
Grinding option	0,15 mm x 10 times
Precision	0,01 mm
Dimensions	150 x 150 x 250 mm
Gross weight	15 kg

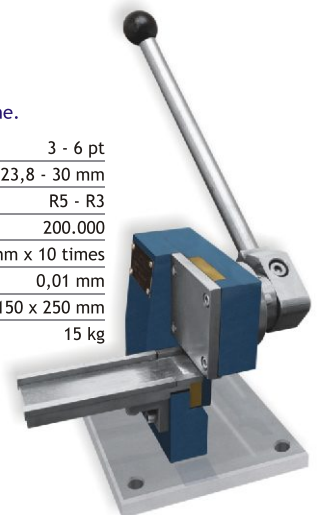

UNIQUE is a young, dynamic producer of diemaking equipment. Being a division of Turkey's leader diemaker Ozkardesler A.Ş., the brand focuses on solving industry's major troubles related to processing of steel cutting rules looking from a unique perspective.

Inspired by an innovative diemaking team, UNIQUE has been constantly equipping conventional manual equipment with smart features that boost efficiency and make them user friendly. Starting from 1,5pt thick 8mm high cutting rules up to 6pt thick 100mm high cutting rules, UNIQUE offers the most comprehensive range of manual cutters, benders and notchers.

**COATING WITH TITANIUM
(Cutting and notching machines)**

Cutter Blades are made of powder steel and are processed through the most suitable heat treatment. In order to increase the resistance of the cutting blades against corrosion all our blades are covered with TiN (titanium nitride). TiN coating provides a 50-70% increase in part's lifetime and as it is protected against side strokes, the life of the cutter blade is lengthen up to 4-5 times.

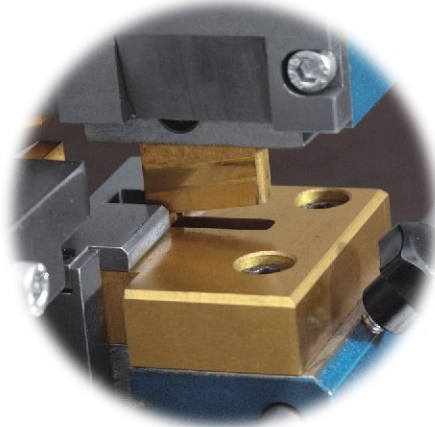

**DIGITAL CALIPER
(Cutting and bending machines)**

For the best length accuracy, all cutters are equipped with digital caliper which allows fast measurements with the precision of 0,01mm. Except for cutters, the foot operated benders are also equipped with digital caliper.



**NO MORE CORROSION AND RUSTING
(All Machines)**

All mechanical parts and the parts in contact with rules are coated with CrN (chrome nitride) which is a special casing type that is resistant against corrosion and rusting for long years. In all Unique eccentric systems, power transmission is carried out by bearings and this prevents the play that may occur in the course of time.

RIGID AND DURABLE (All Machines)

With the purpose of enabling the machine bodies to be resistant against corrosions and strokes for years, they are made of tool steel and sliding blocks are ground precisely.

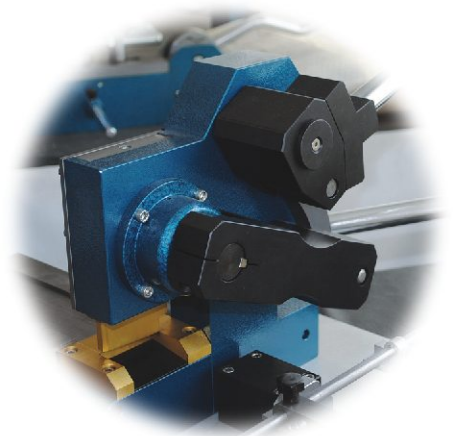

BENDING TOOLS



UB-05 Standard Bending Tools

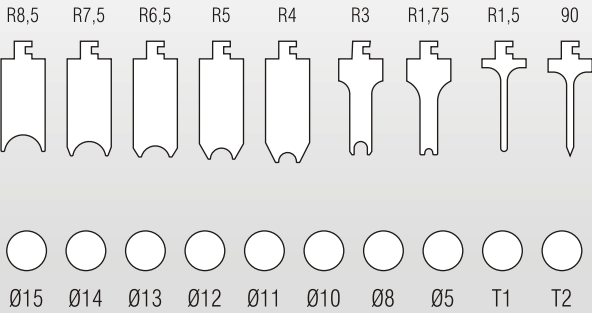

UB-01 Standard Bending Tools

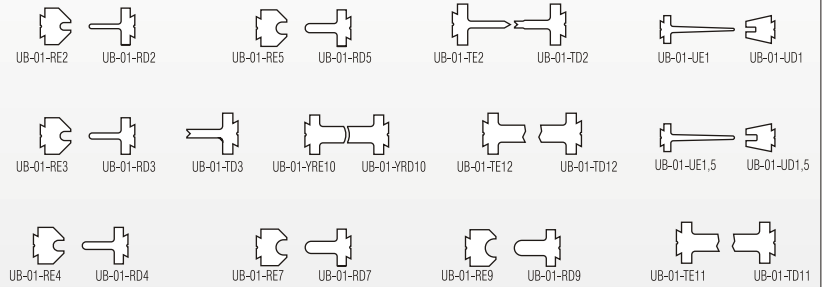

UB-02 2-3 pt. / Up to 40 mm Height Rules Set

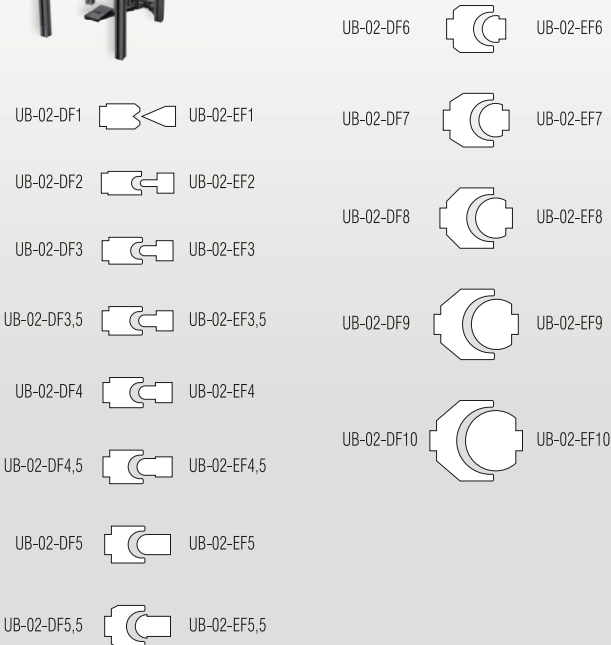

UB-01 Optional Bending Tools

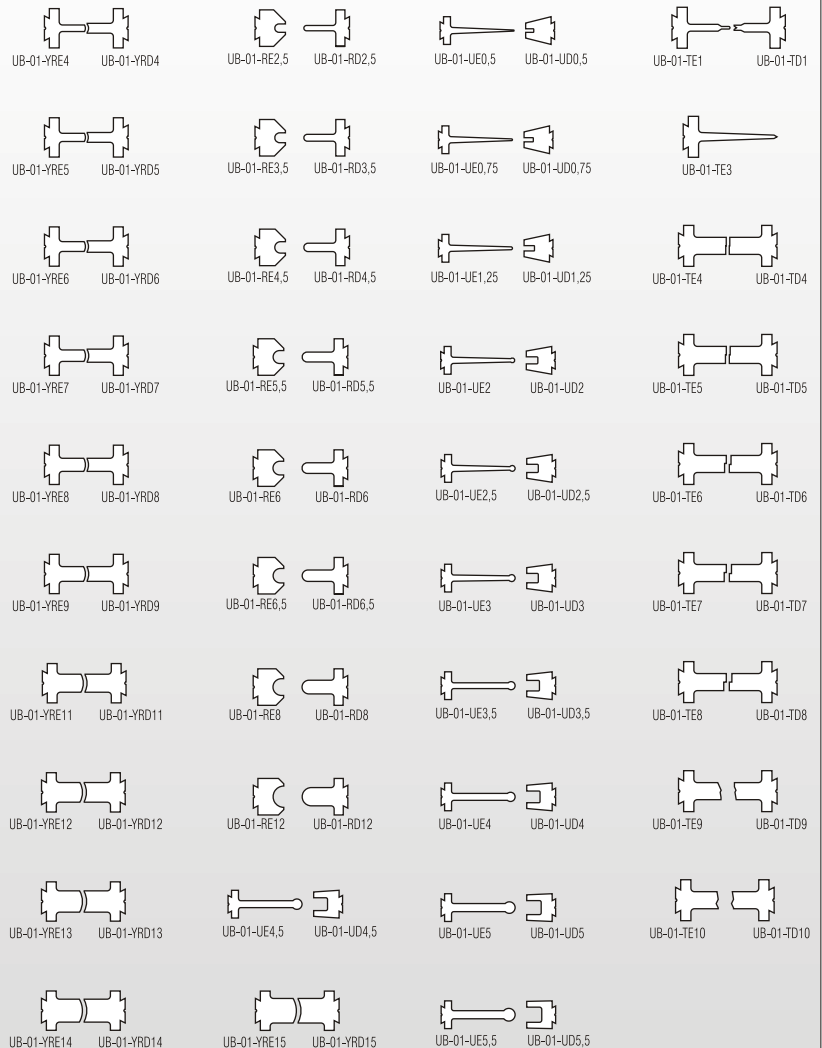

Standard Bending Tool List			
Machine Code	Rule Point	Rule Height	Description
UB-01 Set	1,5 - 3 pt.	23,8 - 30 mm	25 Pcs. Std. Set / (4 pt. opt.)
UB-01 Full Set	1,5 - 3 pt.	23,8 - 30 mm	102 Pcs. Full Set / (4 pt. opt.)
UB-02 2-3 pt. 40 mm Set	2 - 3 pt.	23,8 - 40 mm	26 Pcs. Set / (1,5 pt. opt.)
UB-02 3-4 pt. 50 mm Set	3 - 4 pt.	23,8 - 50 mm	26 Pcs. Set
UB-04 Set	3 - 4 pt.	23,8 - 50 mm	26 Pcs. Set
UB-05 5-15 mm Set	1,5 - 4 pt.	8 - 30 mm	19 Pcs. Set / 5 - 15 mm dia.
UB-05 15-55 mm Set	1,5 - 4 pt.	8 - 30 mm	31 Pcs. Set / 15 - 55 mm dia.
UB-08 Set	3 - 4 pt.	23,8 - 100 mm	23 Pcs. Set / max. 16 mm rad.
UB-08H Set	3 - 4 pt.	23,8 - 100 mm	23 Pcs. Set / max. 16 mm rad.
UB-08H Set	3 - 4 pt.	23,8 - 100 mm	44 Pcs. Set / max. 30 mm rad.

On request specific tools can be manufactured.



Why our products ?

- Rigid, Durable and Long Lasting,
- Efficient,
- High Quality,
- All In-House Production...

All machines are guaranteed
by our firm for a period of 1 year.



www.dicar.eu



European Countries and USA Sales:
DICAR B.V.

P.O. box 533 9200 Drachten Holland
sales@dicar.eu Phone : +31 512 582 682
www.dicar.eu

Manufactured by MEKRON which is a member of Ozkardesler Group